

IP 67

230V
50Hz

230V
60Hz

E 27



Type		Light source	Light source power	Lamp holder type	Weight
230V / 50Hz	230V / 60Hz				
STP 76 - 1070	STP 76 - 1071	sodium lamp	70 W	E 27	6,9 kg

Application
decks, holds, industrial areas, etc.

Approvals
according to the rules of relevant classification societies, additional IEC

Housing
stainless steel seamless deep drawn, powder coated white

Diffuser
safety glass

Reflector
aluminium anodized

Lamps (not included)
high pressure sodium (HPS) lamp, Electric
230V, flexible wiring, high temperature resistant

Cable entry
junction box, 1 cable glands brass, M 24x1.5, with earthing insert

Mounting
adjustable bracket, stainless steel, 4 mounting holes, $\varnothing 10$ mm and $\varnothing 14$ mm

Electrical connection
see finish section

1.01

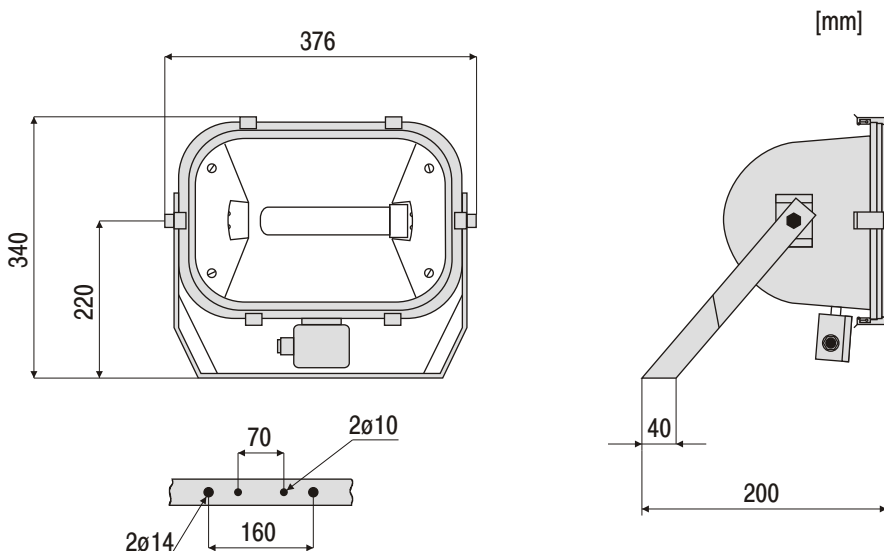

OPTIONS

SC-Glands for screen cable 



Floodlight with incorporated ballast, 1x70W for HPS

STP 76 - 1070

Spare parts for floodlight STP 76-1070

No.	Spare parts	Part-no.
1	Glass mounting kit	101 00 76107
2	Reflector	201 00 76107
3	Lampholder E 27	011 00 76107
4	Ignitor	021 00 76107
5	Ballast	031 00 76107
6	Stainless steel clamps /cpl./	306 00 76107
7	Bracket stainless steel	401 00 76107
8	Junction box	501 00 76107

1.02