



Type	Light source	Light source power / lamp base	Weight
DLP 94	cold beam reflector halogen lamp	20-50W/GU 5.3	0,15 kg

Approvals
according to the rules of relevant classification societies, additional IEC

Housing
die - cast gold plated, chrome plated, white painted, other colours on request

Lamps (not included)
cold beam reflector halogen lamp
20 - 50W

Electric
12V, flexible wiring, heat resistant up to + 250°C

Connections
plug and socket /Wieland GST/
Mounting

with 2 fixing clips
Electrical connection
see finish section

Remark
electronic transformer ET - has to be ordered separately

IP 20

12V

GU 5,3



6.13

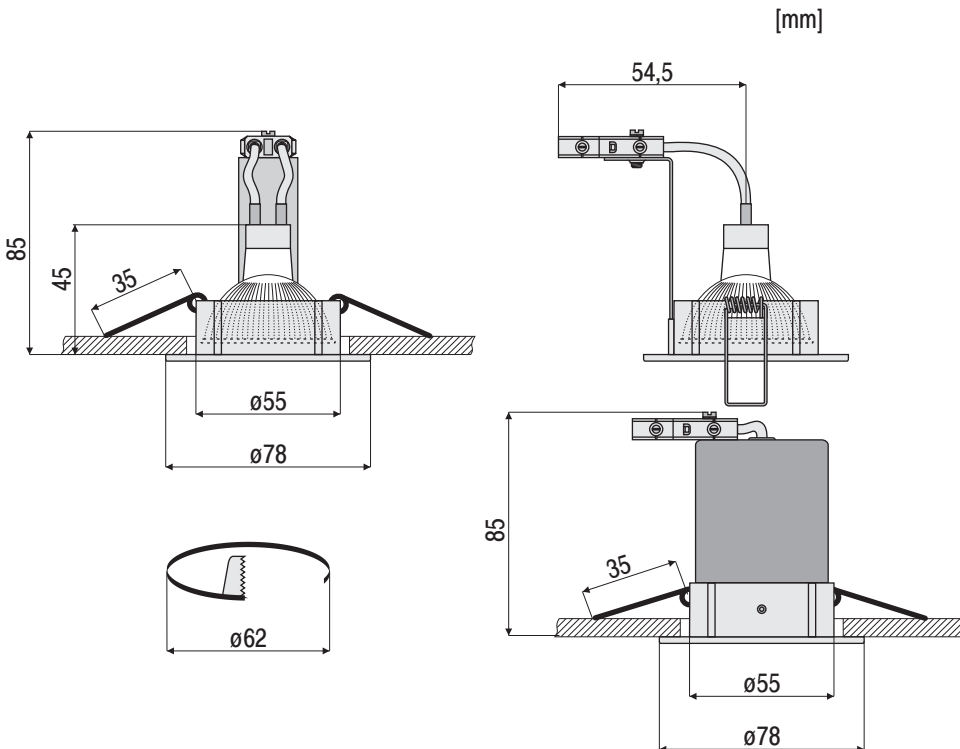

OPTIONS

Electronic Transformer 220V-240V 50Hz-60Hz

Thermo - protected Housing



Order Specification

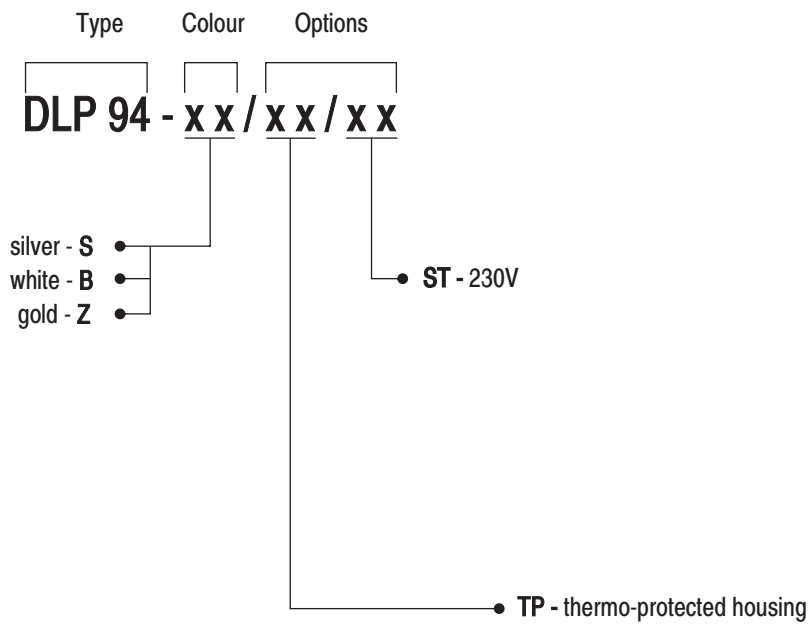

Example of type description

DLP 94 - Z light fitting for cold beam reflector halogen lamp max 50W with socket GU 5.3; colour - gold

6.14