

**IP 44**

220V-250V  
50Hz-60Hz

**2G7**



**2G11**



Type	Light source	Light source power / lamp base	Weight
DEP 30 - 2110	tubular compact fluorescent lamp	2 x 9 W/11W / 2 G 7	2,3 kg
DEP 30 - 2180	tubular compact fluorescent lamp	2 x 18 W / 2 G 11	2,3 kg

**Application**  
passage ways, cabins, lounges, dining rooms, accommodation areas

**Approvals**  
according to the rules of relevant classification societies, additional IEC

**Protection class**  
IP 44 in conjunction with ceiling

**Housing**  
zinc coated steel, powder coated white

**Diffuser**  
polycarbonate, opal

**Lamps (not included)**  
fluorescent lamp 9W; 11W; 18W

**Electric**  
flexible wiring, heat resistant up to +105°C

**Cable entry**  
4 inlets, cable  $\varnothing$  max 11 mm

**Mounting**  
4 mounting holes,  $\varnothing$  5.5 mm, cut out 250 x 250 mm

**Electrical connection**  
see finish section

# 3.03

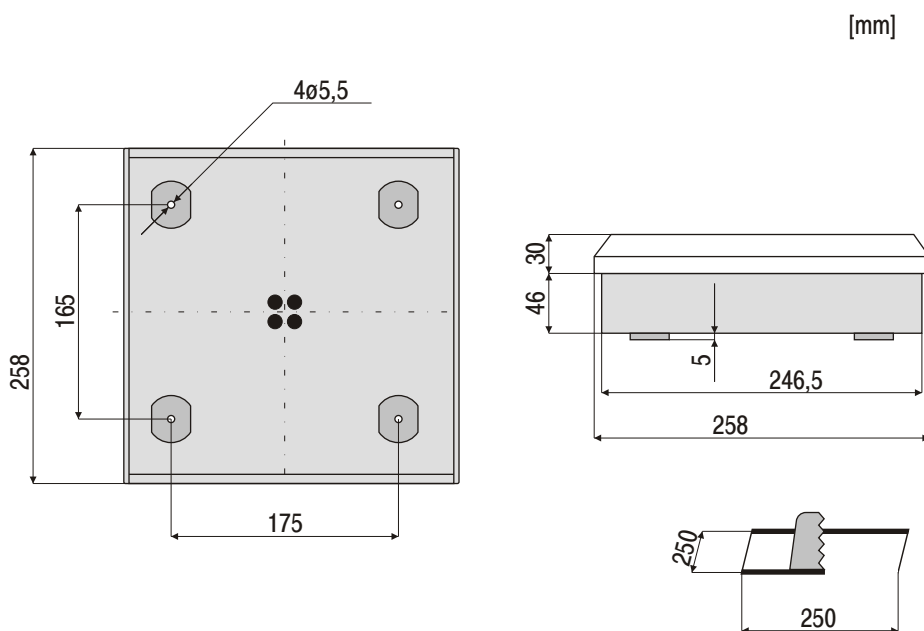

## OPTIONS

120V  
60Hz

24V DC

Battery Backup System 220V-240V 50Hz-60Hz

1h or 3h

Emergency Lampholder B15d

## Order Specification

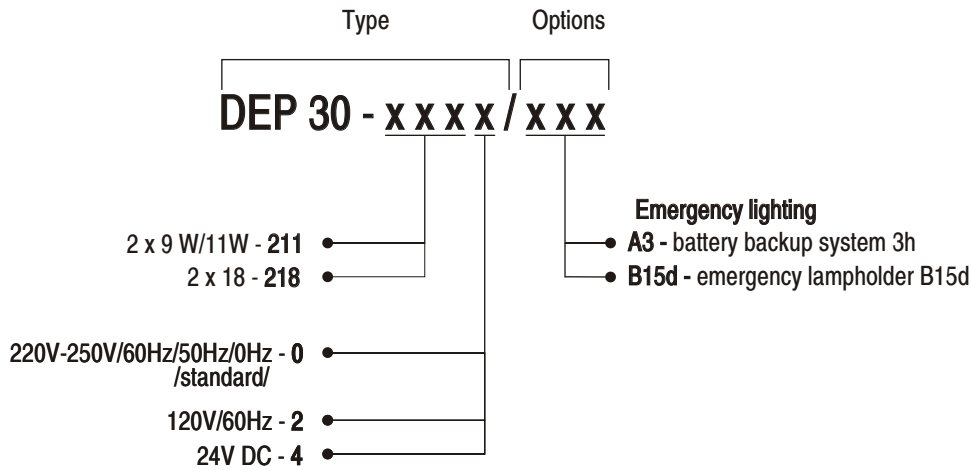

Example of type description

**DEP 30 - 2110** light fitting for two fluorescent lamp 11W with socket 2G7; supply voltage 220V-250V/60Hz/50Hz/0Hz

3.04

**Spare parts for ceiling luminaire DEP 30 - 2...**

No.	Spare parts	Part-no.
1	Diffuser PC, opal	101 00 35000
2	Lampholder 2G7 /2 pcs./	012 00 35009
3	Lampholder 2G11 /2 pcs./	031 00 35211
4	Ballast /1 x 11W/ /2 pcs./	031 00 35211
5	Ballast /1 x 18W/ /2 pcs./	031 00 35218